



UNIVERSITAT POLITÈCNICA
DE CATALUNYA

Optical
Communications
Group



Solving Routing and Spectrum Allocation Related Optimization Problems

Luis Velasco, Alberto Castro, Marc Ruiz
lvelasco@ac.upc.edu



- I. RSA Basics**
- II. Solving Techniques**
- III. Advanced RSA**
- IV. Off-line Network Planning**
- V. In-operation Network Planning**



UNIVERSITAT POLITÈCNICA
DE CATALUNYA

Optical
Communications
Group



Part I

RSA basics

Luis Velasco

Flexgrid

- Flexgrid uses a finer spectrum granularity.
 - The optical spectrum is divided into frequency slices (e.g. 6.25GHz).
- It brings features that are not offered by the fixed grid networks, such as
 - **flexible** bandwidth allocation.
 - transporting optical connections with a capacity **beyond 100Gb/s**
 - **elasticity** against time-varying traffic.

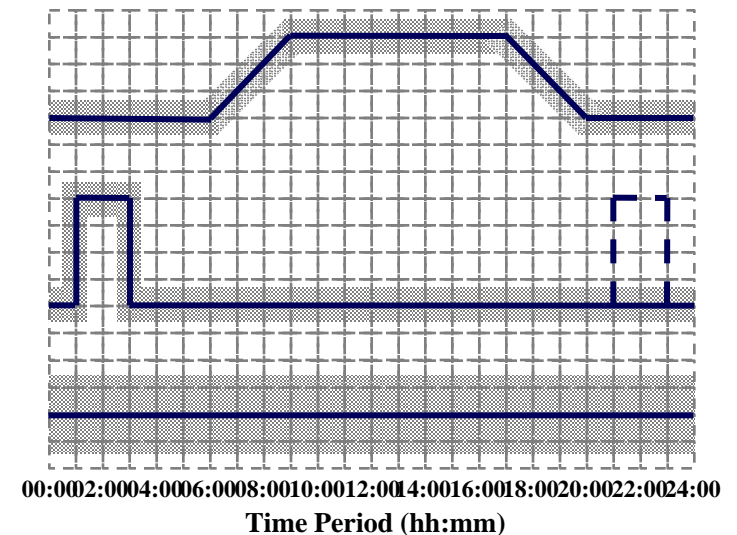
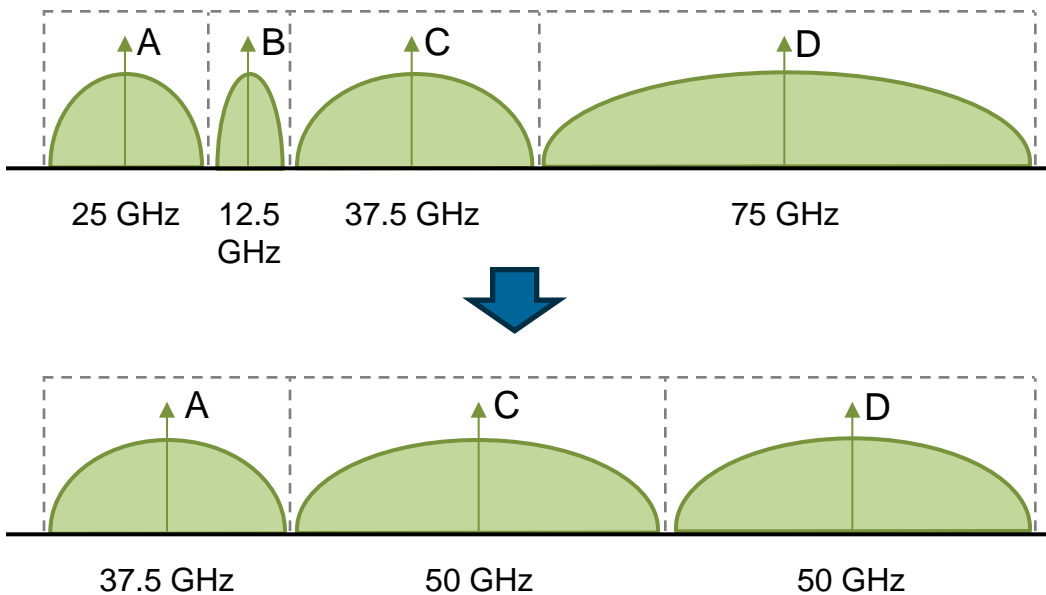

Spectrum allocation

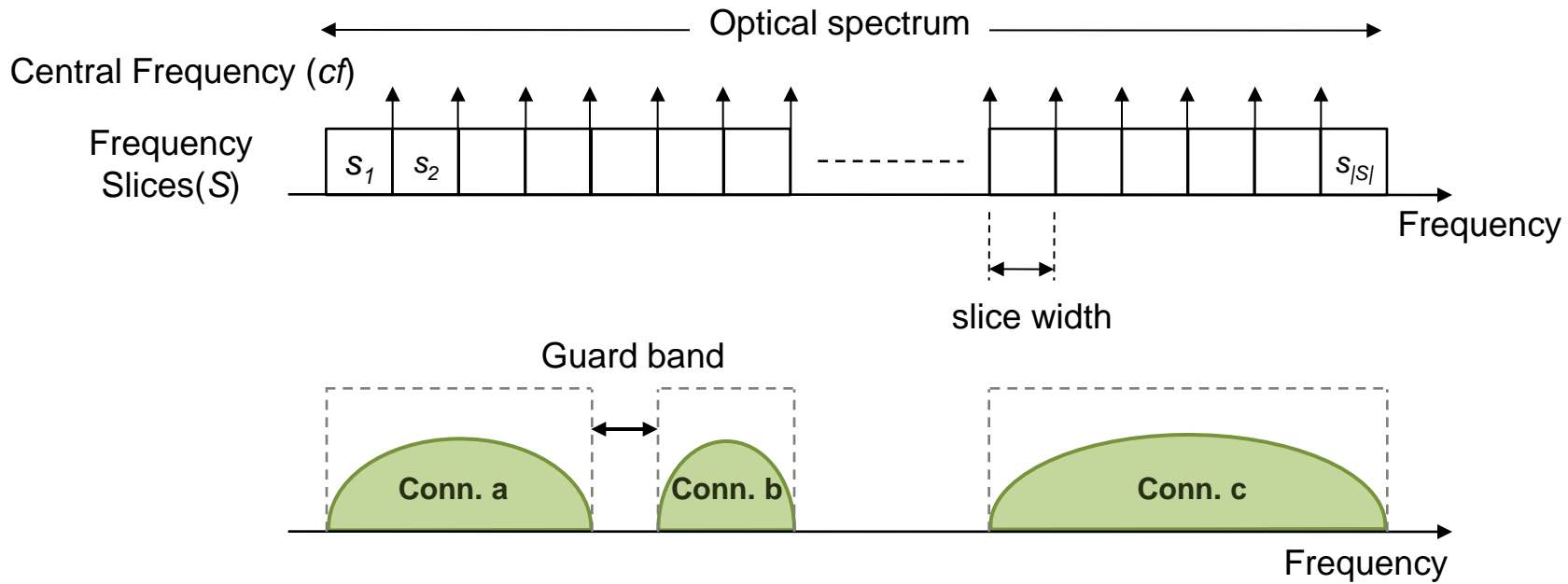

Spectrum allocation entail dealing with two constraints:

- **spectrum continuity** along the links of a given routing path: the same slices must be used in all links of the path,
- **spectrum contiguity**: the allocated slices must be contiguous in the spectrum.

Slices and Channels

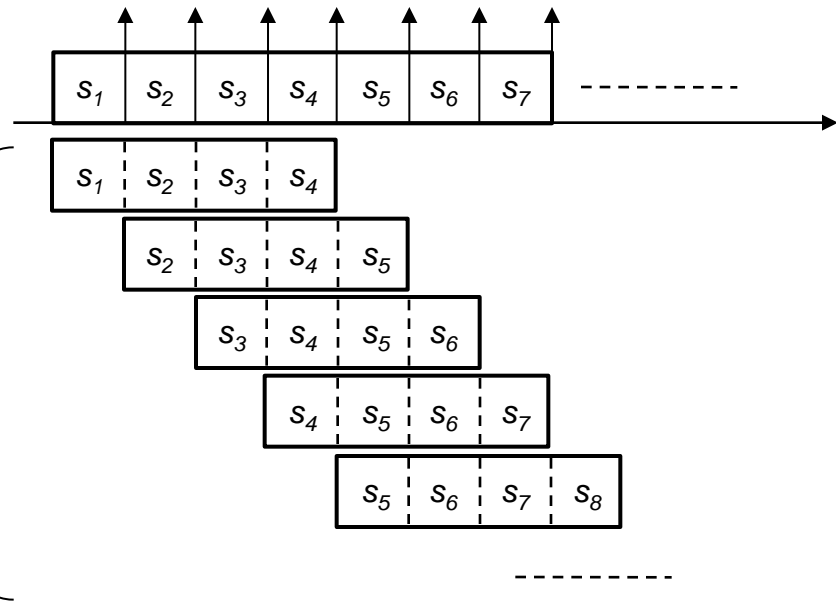
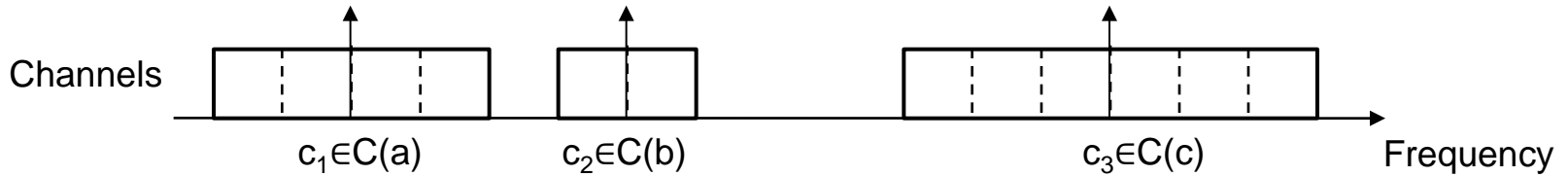

$C(d)$ pre-computation

INPUT S, d	
OUTPUT $C(d)$	
1:	Initialize: $C(d) \leftarrow 0_{[S -n_d+1 \times S]}$
2:	for each i in $[0, S -n_d]$ do
3:	for each s in $[i, i+n_d-1]$ do
4:	$C(d)[s]=1$
5:	return $C(d)$

Basic RSA Problem Statement

Demand Matrix

From	To	BW



Lightpaths

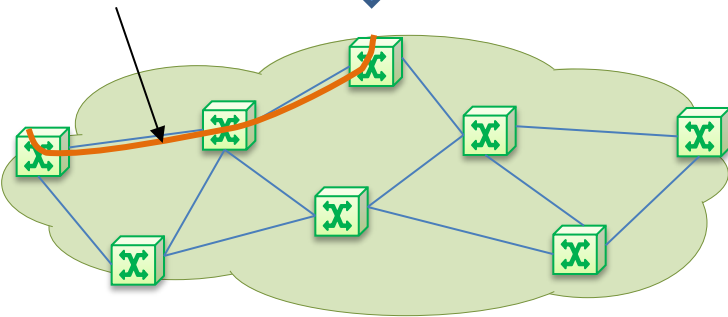

Flexgrid

- Given:
 1. a set N of locations and a set of optical fibers E connecting those locations;
 2. the characteristics of the optical spectrum (i.e., spectrum width, frequency slice width) and the set of modulation formats;
 3. a traffic matrix D with the amount of bitrate exchanged between each pair of locations in N ;
- Output: the **Route and Spectrum Allocation** for each demand in D .
- Objective: one or more among:
 - Minimize the amount of bitrate blocked,
 - Minimize the total amount of used slices,
 - Minimize the total number of links used,
 - etc.

Link-path Channel Assignment Formulation

Pre-computed Parameters

- $P(d)$ Set of predefined candidate paths for demand d .
- $C(d)$ Set of channels for demand d .
- δ_{pe} Equal to 1 if path p uses link e , 0 otherwise.
- γ_{cs} Equal to 1 if channel c includes slice s , 0 otherwise.

Variables

- x_d Binary. Equal to 1 if demand d is rejected, 0 otherwise.
- y_{pc} Binary. Equal to 1 if channel c is assigned to path p and 0 otherwise

$$(LP - CA) \quad \min \quad \sum_{d \in D} x_d \cdot b_d$$

$O(|P(d)| \cdot |D| \cdot |C|)$ variables
 $O(|D| + |E| \cdot |S|)$ constraints

subject to:

$$\sum_{p \in P(d)} \sum_{c \in C(d)} y_{pc} + x_d = 1 \quad \forall d \in D$$

$$\sum_{d \in D} \sum_{p \in P(d)} \sum_{c \in C(d)} \gamma_{cs} \cdot \delta_{pe} \cdot y_{pc} \leq 1 \quad \forall e \in E, s \in S$$

Solved using CPLEX

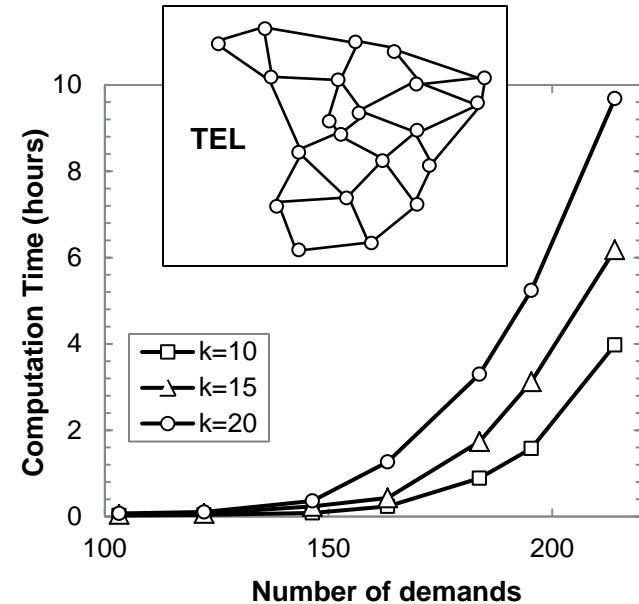
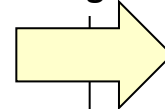

* L. Velasco, et al., "Modeling the Routing and Spectrum Allocation Problem for Flexgrid Optical Networks," Springer Photonic Network Communications, 24, 177-186, 2012

Topology Design as a RSA Problem

- Given:

1. a connected graph $G(N,E)$, where N is the set of locations and E the set of optical fibers;
2. the characteristics of the optical spectrum and modulation formats;
3. a traffic matrix D ;

- Output:

1. The route and spectrum allocation for each demand in D .
2. **The links that need to be equipped;**

- Objective: **Minimize number of links to be equipped** to transport the given traffic matrix.

Node-link CA Formulation

Variables

- w_{dec} Binary. Equal to 1 if demand d uses channel c in link e , 0 otherwise
 z_e Binary. Equal to 1 if link e is opened, 0 otherwise

$$(NL - CA) \quad \min \quad \sum_{e \in E} z_e$$

subject to:

$$\sum_{e \in E(v)} \sum_{c \in C(d)} w_{dec} = 1 \quad \forall d \in D, v \in \{s_d, t_d\}$$

$$\sum_{e \in E(v)} \sum_{c \in C(d)} w_{dec} \leq 2 \quad \forall d \in D, v \notin \{s_d, t_d\}$$

$$\sum_{\substack{e' \in E(v) \\ e' \neq e}} w_{de'e} \geq w_{dec} \quad \forall d \in D, c \in C(d), v \notin \{s_d, t_d\}, e \in E(v)$$

$$\sum_{d \in D} \sum_{c \in C(d)} \gamma_{cs} \cdot w_{dec} \leq 1 \quad \forall e \in E, s \in S$$

$$\sum_{d \in D} \sum_{c \in C(d)} w_{dec} \leq |S| \cdot z_e \quad \forall e \in E$$

$O(|D| \cdot |E| \cdot |C|)$ variables

$O(|D| \cdot |C| \cdot |V| \cdot |E|)$ constraints

* L. Velasco, et al., "Modeling the Routing and Spectrum Allocation Problem for Flexgrid Optical Networks," Springer Photonic Network Communications, 24, 177-186, 2012

Network Dimensioning as a RSA Problem

- Given:

1. a connected graph $G(N,E)$, where N is the set of locations and E the set of optical fibers;
2. the characteristics of the optical spectrum and modulation formats;
3. a traffic matrix D ;
4. **the cost of every component, such as optical cross-connects (OXC) and transponder (TP) types specifying its capacity and reach.**

- Output:

1. The route and spectrum allocation for each demand in D .
2. **Network dimensioning including the type of OXC and TPs in each location;**

- Objective: **Minimize the total cost** to transport the given traffic matrix.



UNIVERSITAT POLITÈCNICA
DE CATALUNYA

Optical
Communications
Group



Part II

Solving Techniques

Luis Velasco

Heuristics

- RSA problems are *NP-hard*, so there is little hope of ever finding efficient exact solution procedures for them.
- Un-tractability of MILP formulations appears when instances to be solved involve a large number of variables.
 - Tens of nodes x Tens of links x Hundreds of slots x Hundreds of demands = Millions of binary variables.
- Heuristics, i.e., **approximate solution techniques**, can be used to tackle RSA-based (combinatorial) problems.

Ω Solution space

$f: \Omega \rightarrow \mathbb{R}$ Objective function defined on the solution space

goal: find $\omega^* \in \Omega, f(\omega) \geq f(\omega^*) \forall \omega \in \Omega$

Heuristics

- Heuristic algorithms usually consists on two phases:
 - Constructive Phase, where a solution is built.
 - Local search, where the solution is improved.
- During the **Constructive phase**, greedy algorithms may be used.
- During the **local search** phase, exchanges among elements in the solution and not in the solution are done.

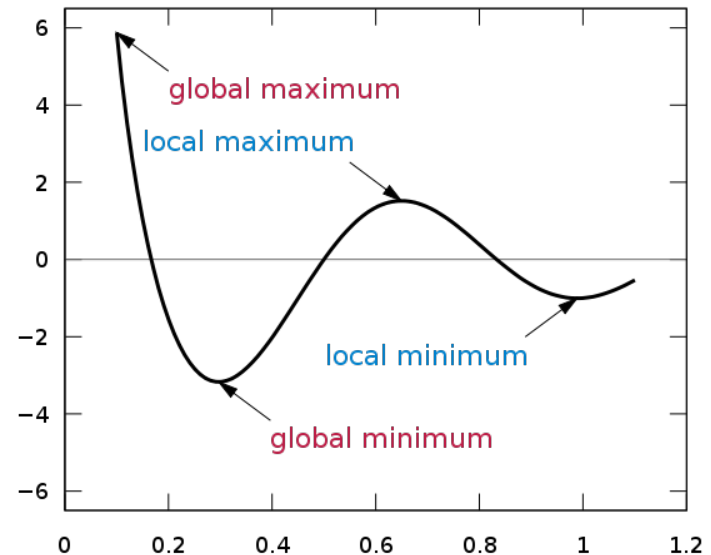
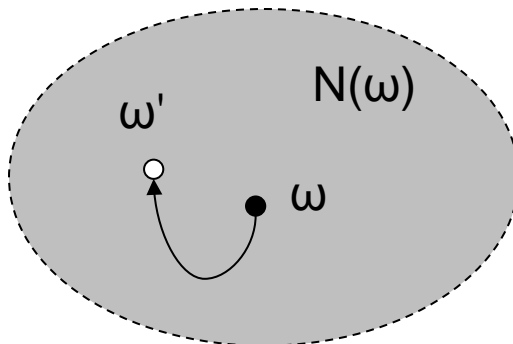

Meta-heuristics

- Meta-heuristics allow go beyond heuristics by:
 - adding variability (randomize)
 - allowing escaping from local optima, at risk of cycling
- Some well-known meta-heuristics are:
 - **GRASP** (Feo and Resende): a multi-start metaheuristic for combinatorial problems.
 - Evolutionary algorithms (genetics). **BRKGA** (M. Resende)
 - **Simulated Annealing**, probabilistic metaheuristic often used when the search space is discrete
 - **Tabu Search** (Fred W. Glover): Enhances the performance of Local search by using memory structures.
 - **Ant colony**: probabilistic technique (Marco Dorigo)
 - **Path relinking**: an *intensification* method.

Hybrid meta-heuristics

- Heuristic hybridization: Combine several of the previous techniques.
 - GRASP + PR -> Diversification + Intensification
- Example: multi-greedy + PR
 - **Three different constructive** algorithms to provide diversification.
 - **Path Relinking** finds new solutions in the path connecting two solutions.

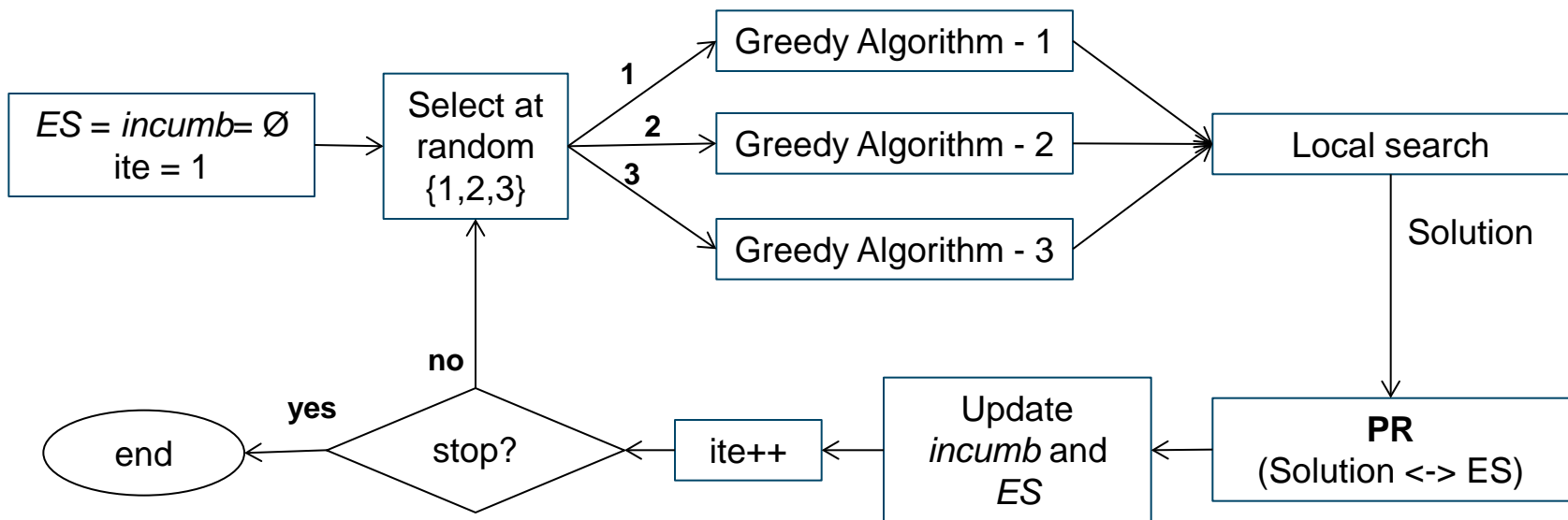

* M. Ruiz, et al., "Ultra-fast meta-heuristic for the spectrum re-allocation problem in flexgrid optical networks", 25th European Conference on Operational Research (EURO XXV), 2012

Hybrid meta-heuristics: Solving Time

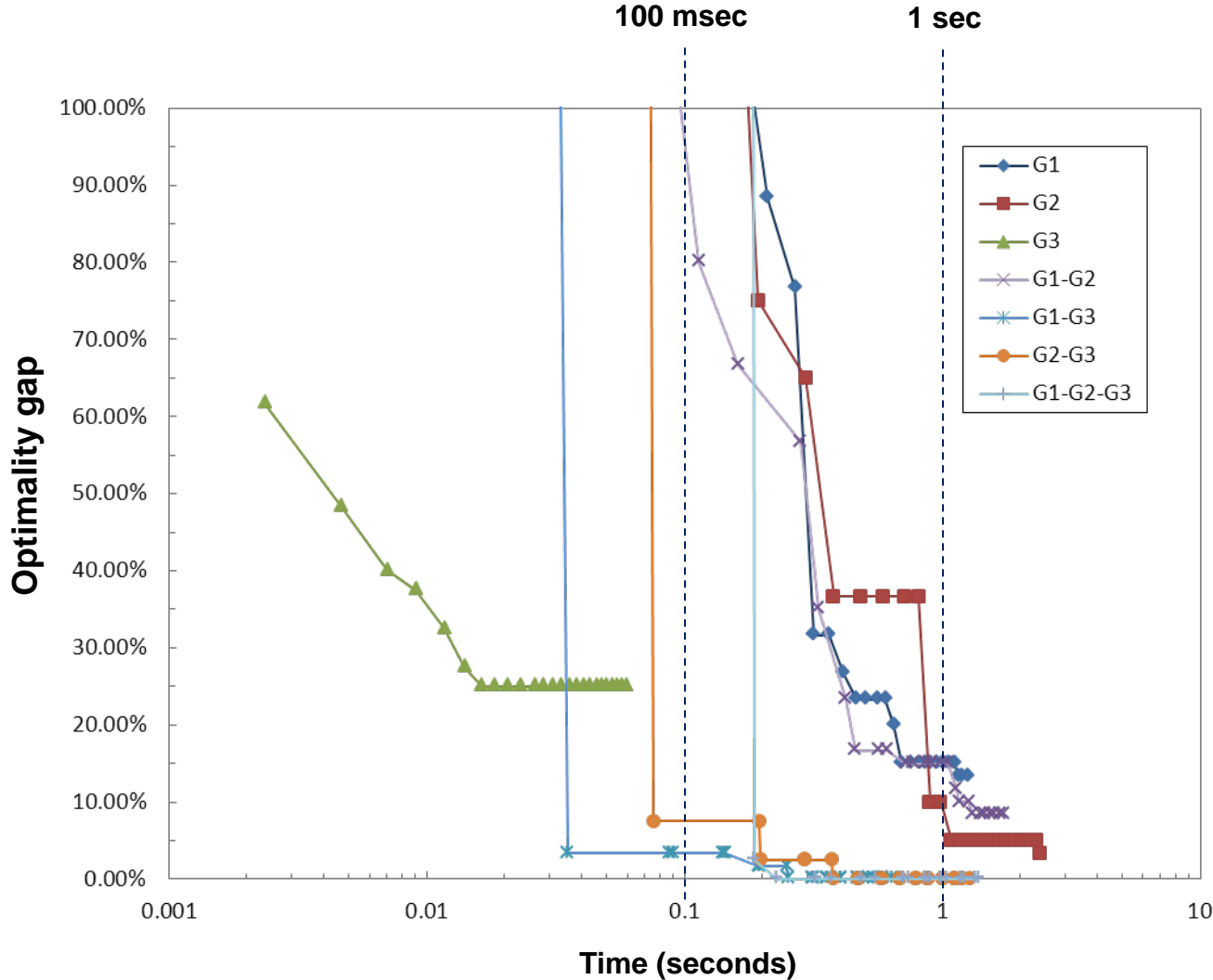

G3 provides feasible solutions in few milliseconds (20-50 msec)

G1 and G2 provide better solutions but at the expense of higher computation time

Multi-start with PR provides the best results:
 (G1 + G3)
 (G2 + G3)
 (G1 + G2 + G3)

Large Scale Optimization (LSO)

- The objective of LSO methods is to extend the exact methodology (Branch & Bound) for MILP formulations.
- Among different methods, decomposition methods have been successfully used for solving communications network design problems
 - **Lagrangian relaxation** aims at improving lower bounds on the objective function, a decisive factor for the effectiveness of Branch & Bound.
 - **Column generation** consists in finding a reduced set of variables (columns) to solve the linear relaxation of the link-path MILP formulations, providing high quality integer solutions in an efficient way.
 - **Benders decomposition** is an iterative procedure based on projecting out a subset of variables from the original problem with the whole set of variables and creating new constraints (cuts) from the projected ones.

Lagrangian Relaxation

- Some (*difficult*) constraints are moved to the objective function and penalized by **Lagrange multipliers** (λ)

$$\begin{array}{ll}
 \min & \sum_{d \in D} x_d \cdot b_d \\
 \text{s.t.} & \\
 & \sum_{p \in P(d)} \sum_{c \in C(d)} y_{pc} + x_d = 1 \quad \forall d \in D \\
 & \boxed{\sum_{d \in D} \sum_{p \in P(d)} \sum_{c \in C(d)} \gamma_{cs} \cdot \delta_{pe} \cdot y_{pc} \leq 1} \quad \forall e \in E, s \in S
 \end{array}$$



$$\begin{array}{ll}
 \min & \sum_{d \in D} x_d \cdot b_d + \boxed{\sum_{e \in E} \sum_{s \in S} \lambda_{es} \cdot \left(\sum_{d \in D} \sum_{p \in P(d)} \sum_{c \in C(d)} \gamma_{cs} \cdot \delta_{pe} \cdot y_{pc} - 1 \right)} \\
 \text{s.t.} & \\
 & \sum_{p \in P(d)} \sum_{c \in C(d)} y_{pc} + x_d = 1 \quad \forall d \in D
 \end{array}$$

- It allows obtaining **lower bounds** for the original problem for any positive Lagrange multipliers.
- Those Lagrange multipliers that provide the optimal solution of the original problem can be found by **solving the Lagrangian dual problem**.
 - Iterative methods such as **sub-gradient optimization** methods are commonly used for solving the Lagrangian dual problem.

Column Generation Algorithm

Main Algorithm

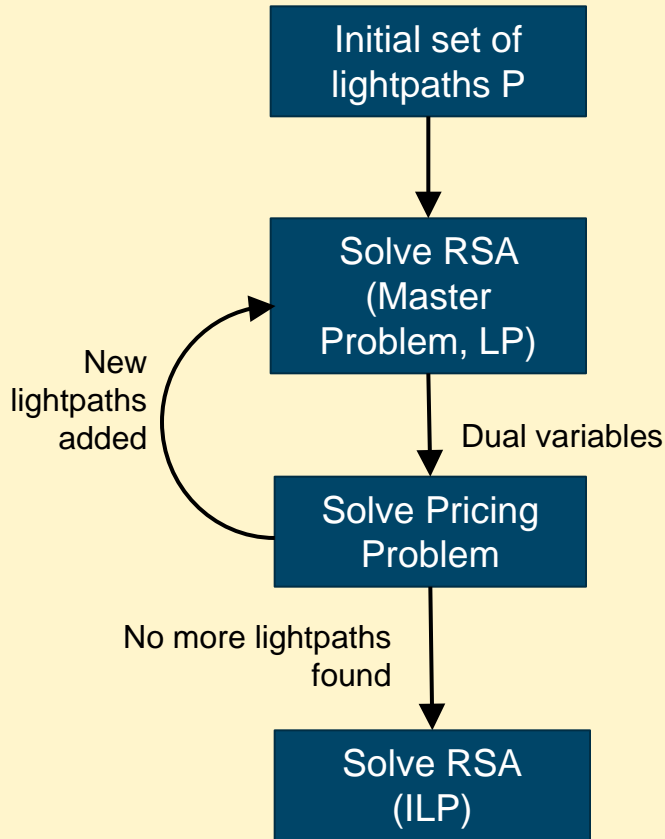

Lightpath set initialization

For each demand d :

- 1) Compute the shortest (hops) path in the network
- 2) Generate a lightpath with the shortest path and the first channel for demand d .

Pricing Problem

- 1) For each demand d and each channel in C_d , compute the shortest path in the network with link metrics:

$$f_e(c) = \sum_{s \in S(c)} \pi_{es} \quad c \in C_d$$

- 2) Return those lightpaths (route + channel) with the highest positive reduced costs (if any)

Exhaustive search of channels optimized by means of Floyd-Warshall algorithm

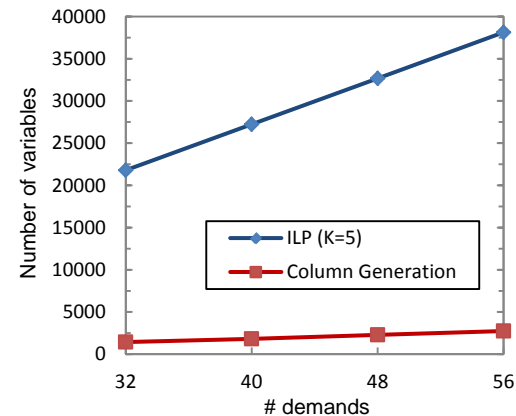
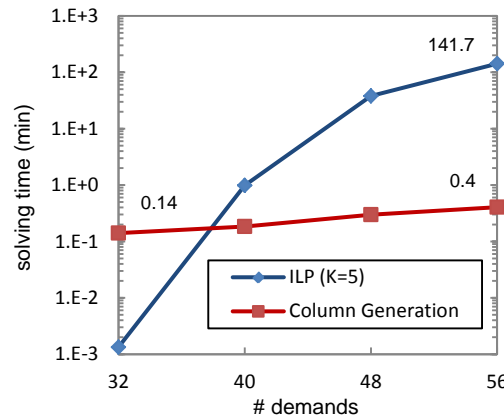

* M. Ruiz, et al., "Column Generation Algorithm for RSA Problems in Flexgrid Optical Networks," Springer Photonic Network Communications, 2013.

The Dijkstra's Shortest Path algorithm

```
Procedure Dijkstra (N, E, source)
begin
  S := {source}, T = N - {source}
  d(source) = 0 and pred(source) = 0
  d(j) = ∞ for each j ≠ source
  update(source)
  while S ≠ N do
    let i ∈ T be a node for which
      d(i) = min {d(j) : j ∈ T}
    S = S ∪ {i}, T = T - {i}
    update(i)
end
```

```
Procedure Update (i)
  for each (i, j) ∈ E(i) do
    if d(j) > d(i) + cij then
      d(j) = d(i) + cij
      pred(j) = i
```

- Each node i is labeled with the aggregated metric $d(i)$ from the source node and with its predecessor $pred(i)$.
- the route $source-i$ (subset of links $E(source, i) \subseteq E$) can be computed visiting the predecessor node starting from i , until source node is reached.

Dijkstra-based RSA (1/2)

```

Procedure Update ( $i$ )
  for each  $(i, j) \in E(i)$  do
    if  $\pi(i, j) = 1$  and  $d(j) > d(i) + c_{ij}$ 
    then
       $d(j) = d(i) + c_{ij}$ 
       $\text{pred}(j) = i$ 
    
```

- The label also contains $\eta_s(i)$, the aggregated state of frequency slice s

$$\eta_s(i) = \prod_{e \in E(\text{source}, i)} \eta_{es} \quad \forall s \in S$$

- The downstream node j of node i updates the label only if at least one channel is available, computing:

$$\pi(e = (i, j)) = \begin{cases} 1 & \exists c \in C(d) : \eta_s(i) \cdot \eta_{es} = 1 \quad \forall s \in S(c) \\ 0 & \text{otherwise} \end{cases}$$

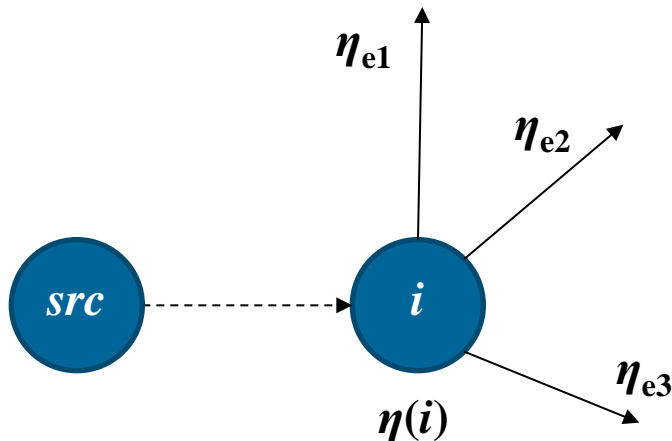

Dijkstra-based RSA (2/2)

- Spectrum allocation can be done implementing any heuristic, such:
 - First Fit
 - Random
 - Least fragmented spectrum
 - etc.
- Modulation formats, reachability, etc, can be easily included.



UNIVERSITAT POLITÈCNICA
DE CATALUNYA

Optical
Communications
Group



Part III

Advanced RSA

Luis Velasco

Source of traffic variations

Reducing aggregation level might increase traffic variations

Datacenter interconnection to transfer bulk data

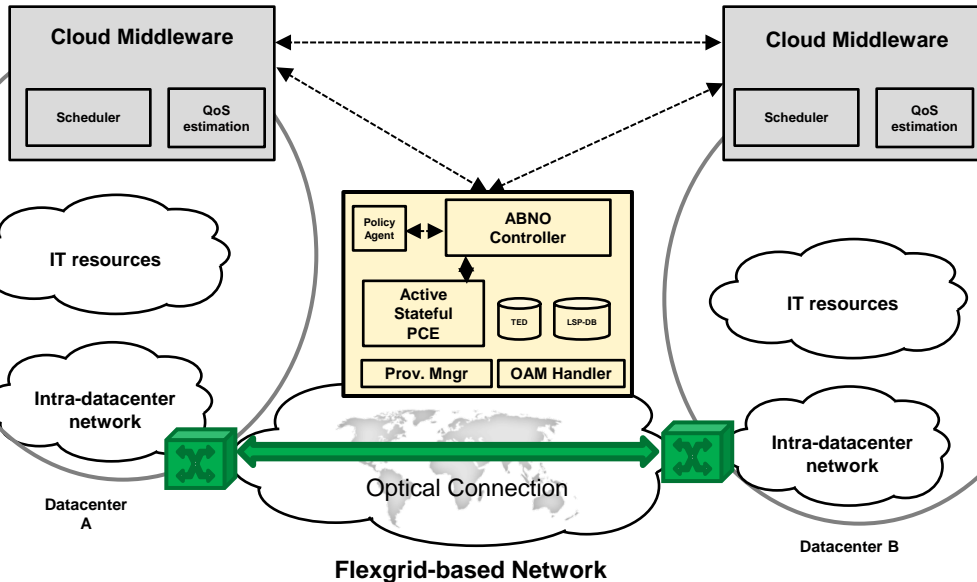
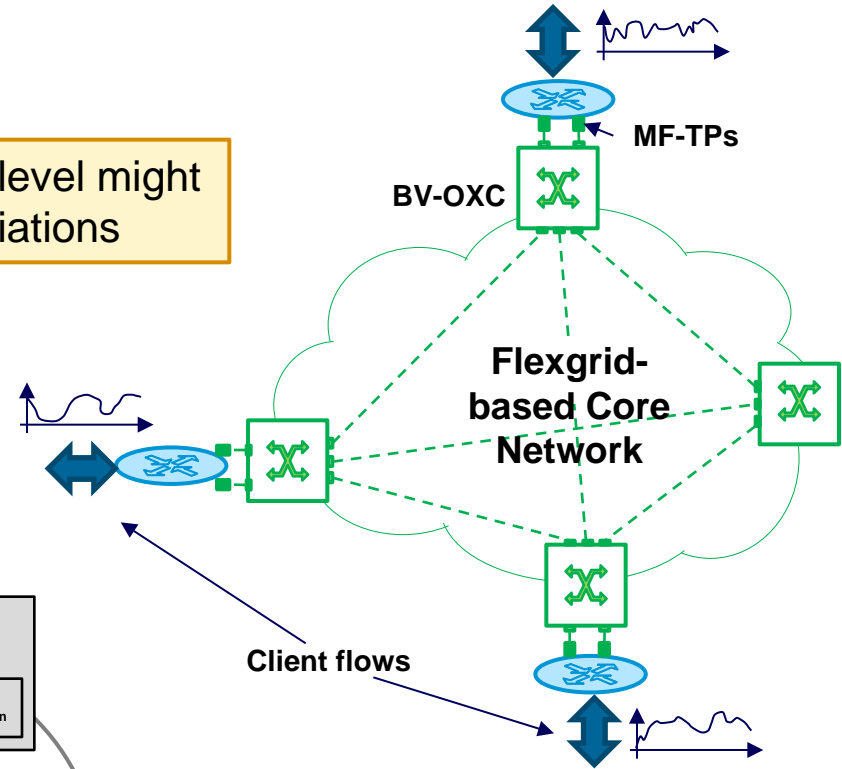

* L. Velasco, et al., "Cross-Stratum Orchestration and Flexgrid Optical Networks for Datacenter Federations," accepted in IEEE Network Magazine, 2013.

Elastic Spectrum Allocation Policies

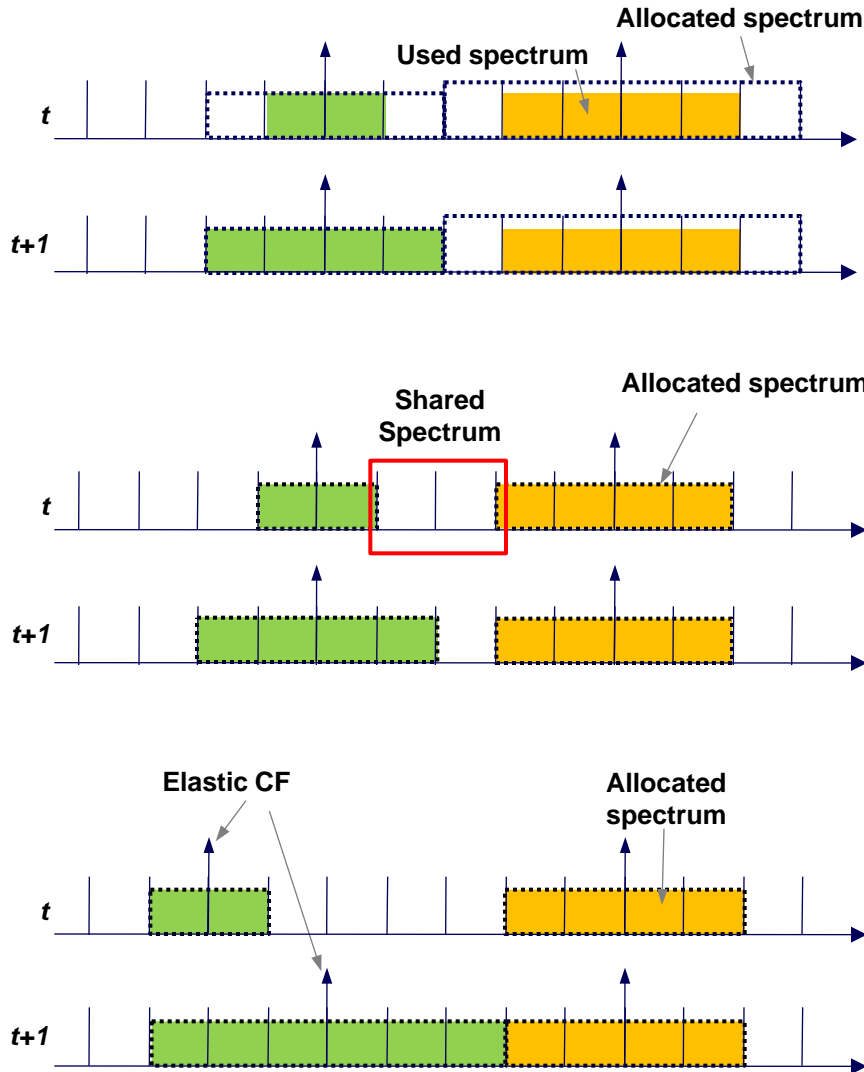

Fixed: both the assigned CF and spectrum width do not change in time.

Semi-Elastic: the assigned CF is fixed but the allocated spectrum may vary.

- At each time interval, the allocated spectrum corresponds to the utilized spectrum.
- Spectrum increments/decrements are achieved by allocating/releasing frequency slices.
- The frequency slices can be shared between neighboring demands, but used by, at most, one demand in a time interval.

Elastic: both the assigned CF and the spectrum width can be subject to change in each time interval.

* M. Klinkowski, et al., "Elastic Spectrum Allocation for Time-Varying Traffic in Flexgrid Optical Networks," IEEE Journal on Selected Areas in Communications (JSAC), vol. 31, pp. 26-38, 2013

Multi-period RSA

- Find, for each demand in D :
 - a route and
 - a **SA for each time period in T** , constraining SA changes to a certain policy.
- Complexity depends on SA policy
 - SA between consecutive time periods is constrained by the chosen policy

RSA

$$\sum_{p \in P(d)} \sum_{c \in C(d)} y_{pc} + x_d = 1 \quad \forall d \in D$$

$$\sum_{d \in D} \sum_{p \in P(d)} \sum_{c \in C(d)} \gamma_{cs} \cdot \delta_{pe} \cdot y_{pc} \leq 1 \quad \forall e \in E, s \in S$$

MP-RSA

$$\sum_{p \in P(d)} x_p + x_d = 1 \quad \forall d \in D$$

$$\sum_{d \in D} \sum_{p \in P(d)} \sum_{c \in C(d)} \gamma_{cs} \cdot \delta_{pe} \cdot y_{pc}^t \leq 1 \quad \forall t \in T, e \in E, s \in S$$

Dynamic lightpath adaptation

- Given:
 - a core network topology represented by a graph $G(N, E)$;
 - a set S of available slices of a given spectral width for every link in E ;
 - a set L of lightpaths already established on the network; each lightpath l is defined by the tuple $\{R_l, f_l, s_l\}$, where the ordered set $R_l \subseteq E$ represents its physical route, f_l its central frequency and s_l the amount of frequency slices.
 - a lightpath $p \in L$ for which spectrum adaptation request arrives and the required number of frequency slices, $(s_p)^{req}$.
- Output:
 - the new values for the spectrum allocation of the given lightpath p : $\{R_p, f_p, (s_p)'\}$ and $\{R_p, (f_p)', (s_p)'\}$, respectively, if the *Semi-Elastic* and *Elastic* policy is used.
- Objective: maximize the amount of bit-rate served.

On-line Algorithms for Elastic SA

INPUT: $G(N,E), S, L, p, (s_p)^{req}$

OUTPUT: $(s_p)'$

- 1: **if** $(s_p)^{req} \leq s_p$ **then** $(s_p)' \leftarrow (s_p)^{req}$
- 2: **else**
- 3: $L^+ \leftarrow \emptyset, L^- \leftarrow \emptyset$
- 4: **for each** $e \in R_p$ **do**
- 5: $L^- \leftarrow L^- \cup \{l \in L: e \in R_l, \text{adjacents}(l, p), f_l < f_p\}$
- 6: $L^+ \leftarrow L^+ \cup \{l \in L: e \in R_l, \text{adjacents}(l, p), f_l > f_p\}$
- 7: $s_{max} \leftarrow 2 * \min \{ \min \{ f_p - f_l - s_l, l \in L^- \}, \min \{ f_l - f_p - s_l, l \in L^+ \} \}$
- 8: $(s_p)' \leftarrow \min \{ s_{max}, (s_p)^{req} \}$
- 9: **return** $(s_p)'$

**Algorithm for the
semi-elastic policy**

**Algorithm for the
elastic policy**

INPUT: $G(N,E), S, L, p, (s_p)^{req}$

OUTPUT: $(f_p)', (s_p)'$

- 1: **if** $(s_p)^{req} \leq s_p$ **then** $(s_p)' \leftarrow (s_p)^{req}; (f_p)' \leftarrow f_p$
- 2: **else**
- 3: $L^+ \leftarrow \emptyset, L^- \leftarrow \emptyset$
- 4: **for each** $e \in R_p$ **do**
- 5: $L^- \leftarrow L^- \cup \{l \in L: e \in R_l, \text{adjacents}(l, p), f_l < f_p\}$
- 6: $L^+ \leftarrow L^+ \cup \{l \in L: e \in R_l, \text{adjacents}(l, p), f_l > f_p\}$
- 7: $s_{max} \leftarrow \min \{ f_p - f_l - s_l, l \in L^- \} + \min \{ f_l - f_p - s_l, l \in L^+ \}$
- 8: $(s_p)' \leftarrow \min \{ s_{max}, (s_p)^{req} \}$
- 9: $(f_p)' \leftarrow \text{findSA_MinCFShifting}(p, (s_p)', L^+, L^-)$
- 10: **return** $\{(f_p)', (s_p)'\}$

* A. Asensio, et al., "Impact of Aggregation Level on the Performance of Dynamic Lightpath Adaptation under Time-Varying Traffic," in Proc. IEEE International Conference on Optical Network Design and Modeling (ONDM), 2013.

Example of Re-optimisation (Defragmentation)

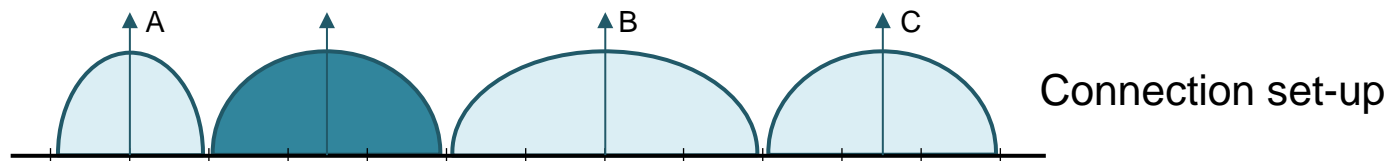
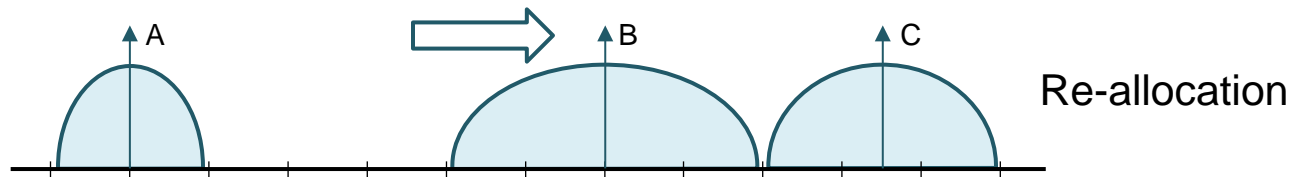
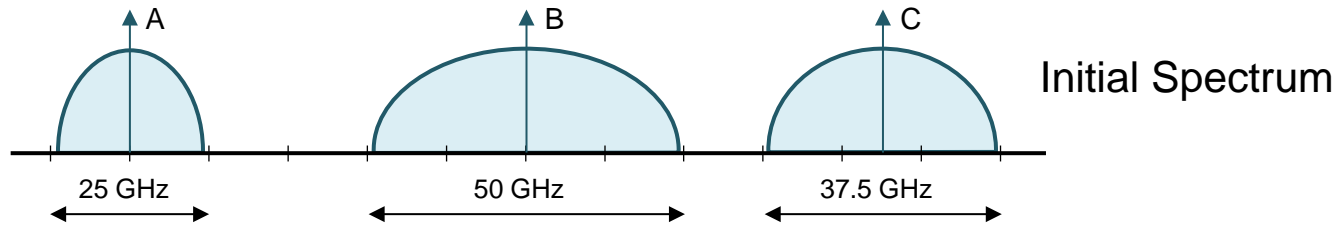
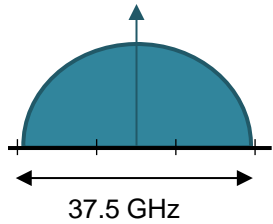

Spectrum Reallocation (SPRESSO)

Parameters

Pm subset of P with the candidate paths, including $newP$. $Pm = P(newP) \cup \{newP\}$.

Variables

x_{pc} binary, 1 if channel c is assigned to path p , 0 otherwise.

y_p binary, 1 if path p is reallocated, 0 otherwise.

r integer with the number of already established paths to reallocate.

(SPRESSO) minimize r

subject to:

$$r = \sum_{p \in Pm \setminus \{newP\}} y_p$$

$$\sum_{c \in C(p)} x_{pc} = 1 \quad \forall p \in Pm$$

$$x_{pc} - \omega_{pc} \leq y_p \quad \forall p \in Pm, c \in C(p)$$

$$\sum_{p \in P(e)} \sum_{c \in C(p)} \delta_{cs} \cdot x_{pc} \leq \eta_{es} \quad \forall e \in E, s \in S$$

$$r \leq \max R$$

$O(|Pm| \cdot |C|)$ variables

$O(|Pm| \cdot |C| + |E| \cdot |S|)$ constraints

* A. Castro, et al., "Dynamic Routing and Spectrum (Re)Allocation in Future Flexgrid Optical Networks," Elsevier Computers Networks, vol. 56, pp. 2869-2883, 2012.

Provisioning-triggered re-optimization

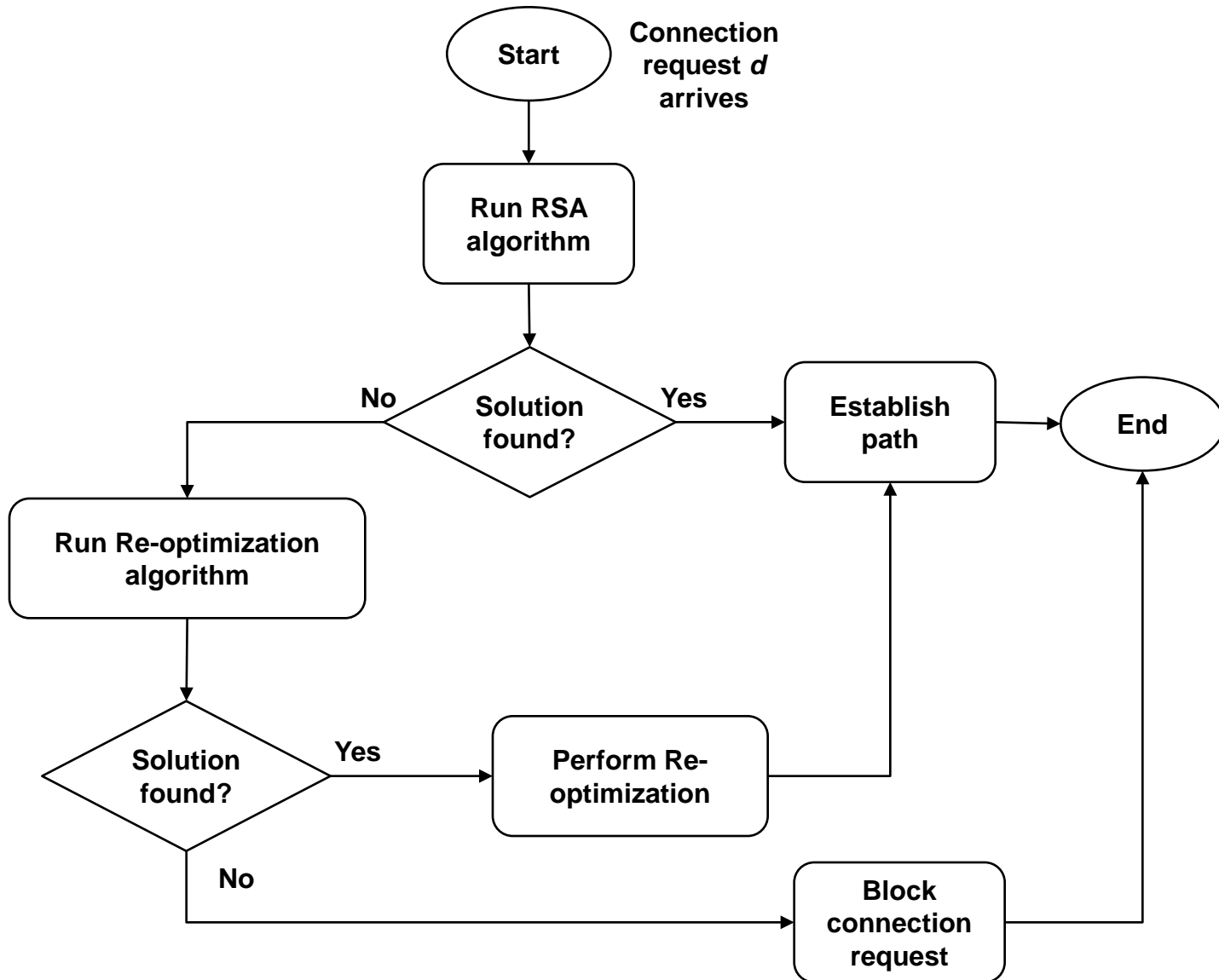

Gains of Using SPRESSO

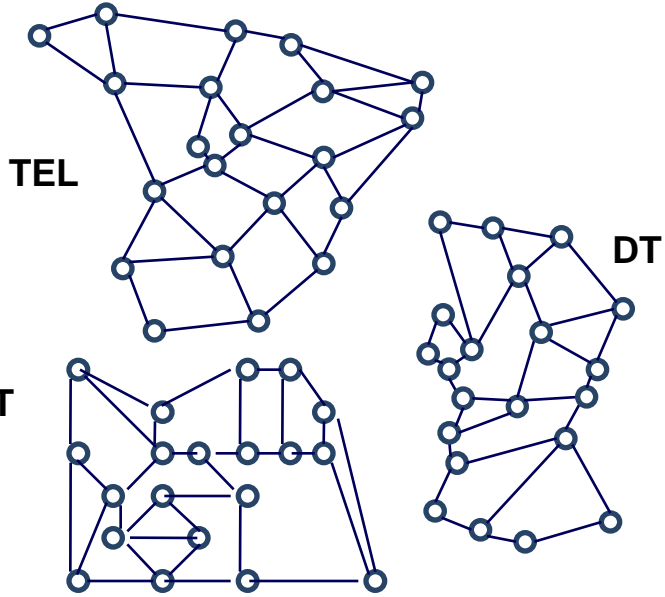

Network	25 GHz	12.5 GHz	6.25 GHz
TEL	30,4%	28,4%	30,3%
BT	22,9%	23,0%	34,1%
DT	22,2%	24,8%	33,0%

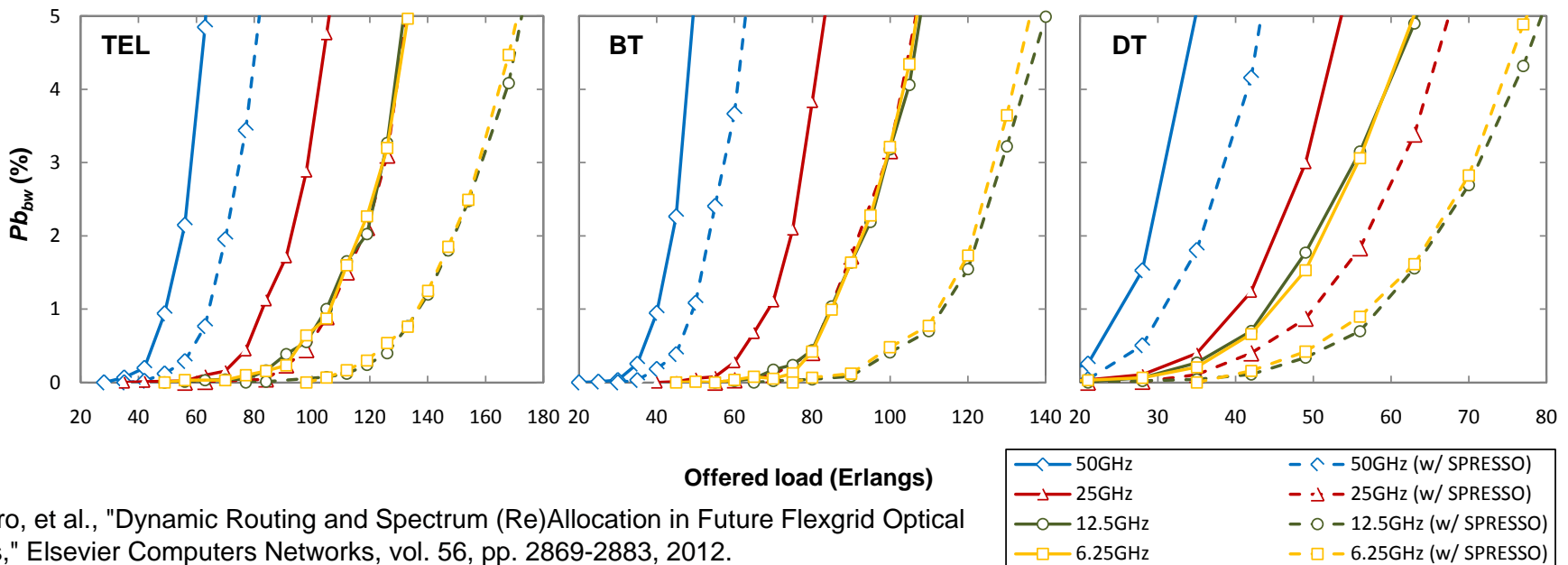

* A. Castro, et al., "Dynamic Routing and Spectrum (Re)Allocation in Future Flexgrid Optical Networks," Elsevier Computers Networks, vol. 56, pp. 2869-2883, 2012.

Bulk path computation

- Path computation for a set of connection requests.
 - the bulk of path requests is computed attaining the optimal solution for the whole set.
 - Increases optimality but increases also provisioning time.
- Bulk path computation can be used for restoration.
 - Reduces resource contention.
 - Increases resource utilization, specially in MLN.
 - Stringent computation times require heuristic algorithms.

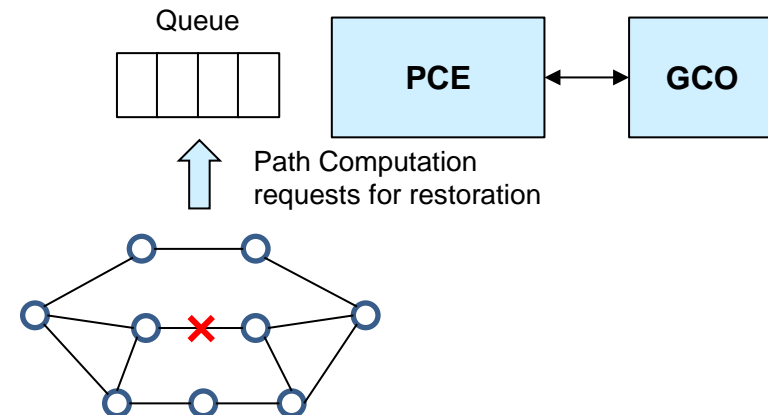

* R. Martínez, et al., "Experimental Validation of Dynamic Restoration in GMPLS-controlled Multi-layer Networks using PCE-based Global Concurrent Optimization," in Proc. IEEE/OSA Optical Fiber Communication Conference (OFC), 2013.

Bitrate Squeezed and Multi-path Recovery

Path Recovery	Description
Protection	Protection routes are known in advance: <ul style="list-style-type: none"> • Dedicated Protection • Shared Protection
Restoration	Restoration routes are found adaptively based on the failure and the state of the network at the time of failure.

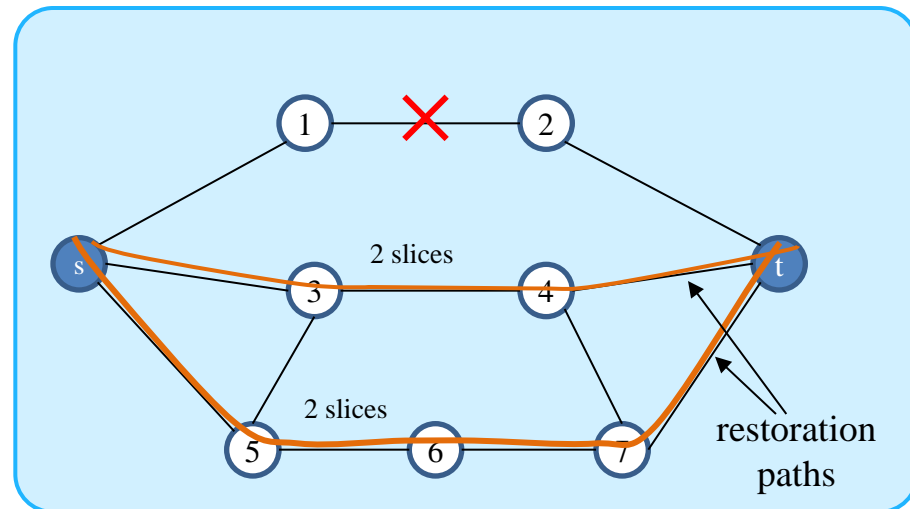
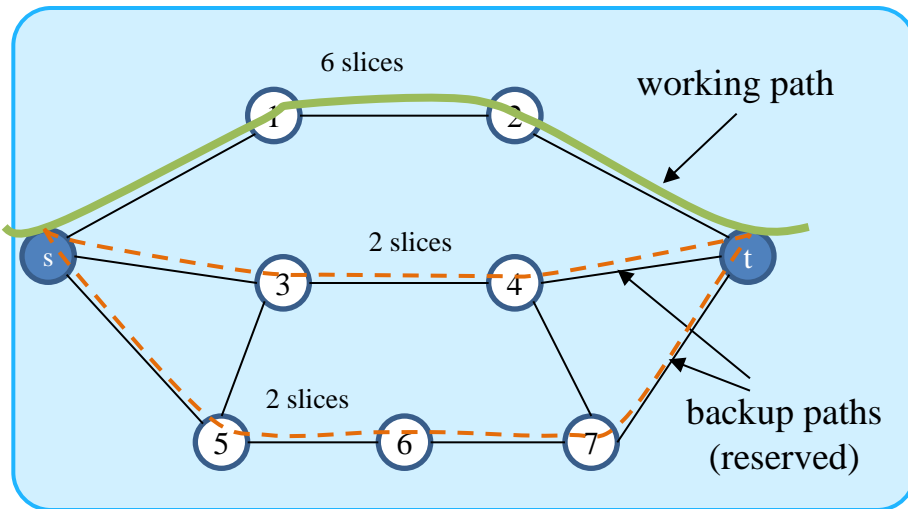

* A. Castro et al., "Single-path Provisioning with Multi-path Recovery in Flexgrid Optical Networks," International Workshop on Reliable Networks Design and Modeling (RNDM), 2012



UNIVERSITAT POLITÈCNICA
DE CATALUNYA

Optical
Communications
Group



Part IV

Off-line Network Planning

Luis Velasco

Network Life Cycle

- Network planning is performed periodically:

- **Capacity** is installed to guarantee that the network can support the forecast traffic.
- **Long planning cycles** are used to upgrade the network and prepare it for the next planning period.
- Results from network capacity planning are **manually deployed** in the network.

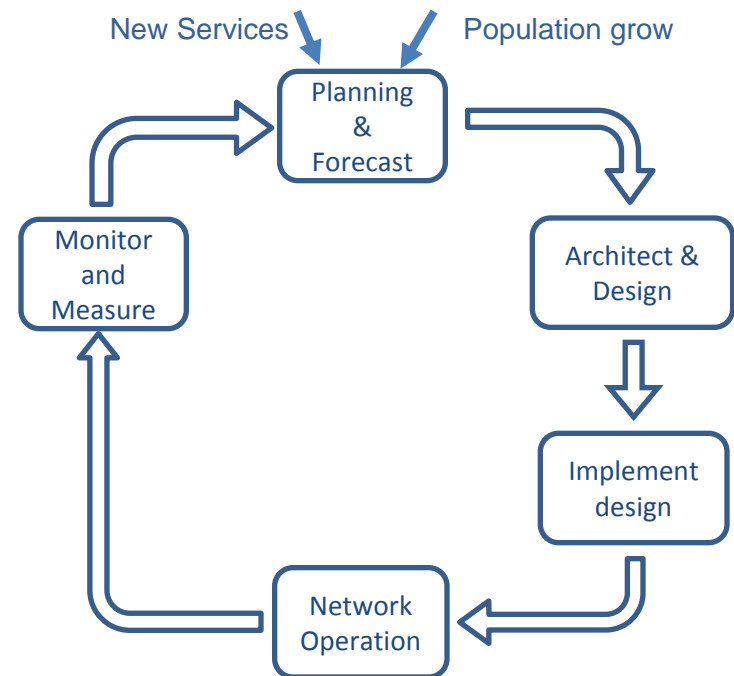

Migrating Towards Flexgrid Technology

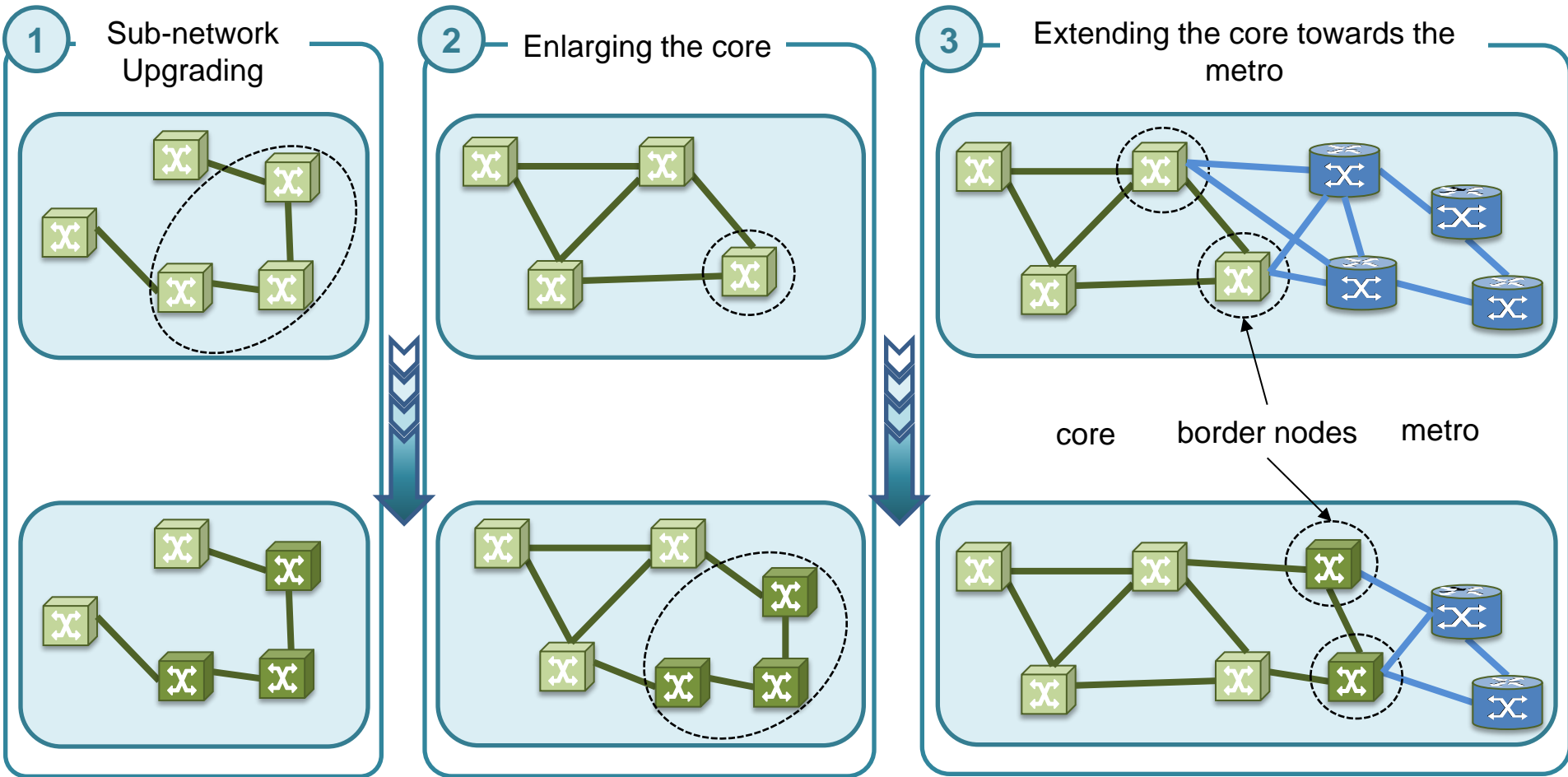

* M. Ruiz, et al, "Planning Fixed to Flexgrid Gradual Migration: Drivers and Open Issues," submitted to IEEE Communications Magazine, 2014.

Migrating connections (1/4)

Fixed grid

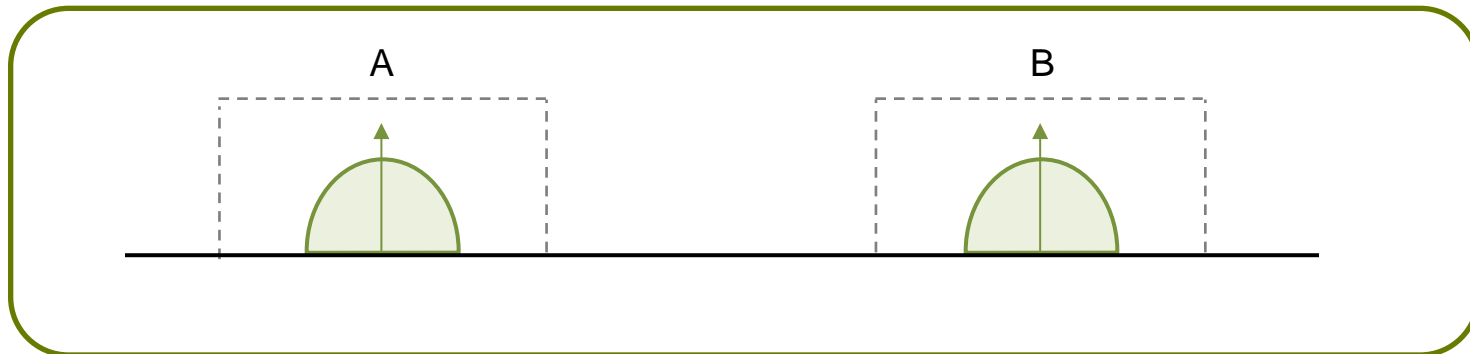
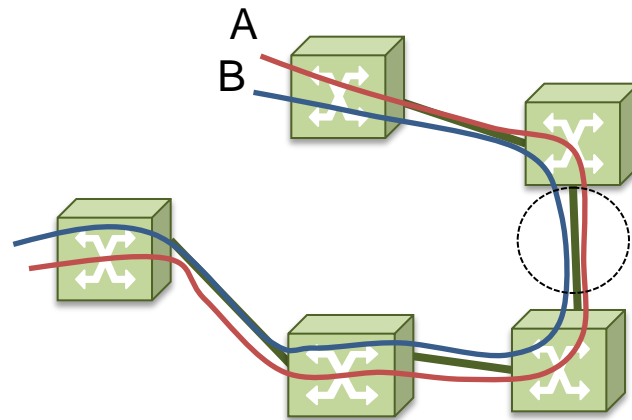

Migrating connections (2/4)

Flexgrid

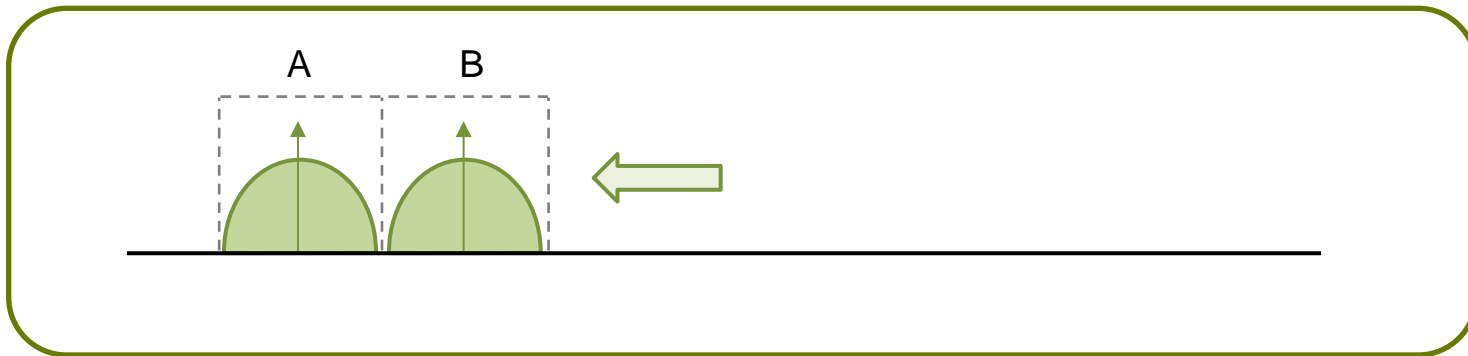
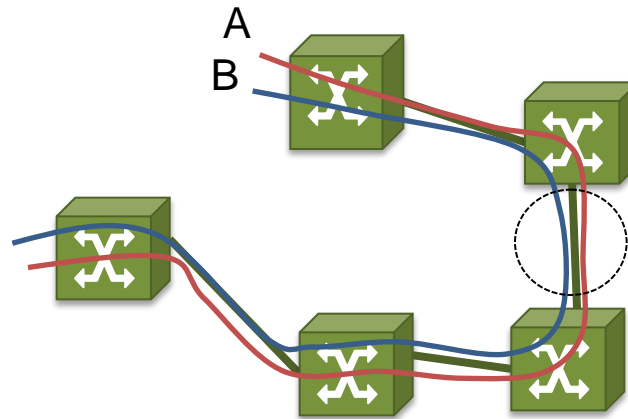

Migrating connections (3/4)

Mixed grid

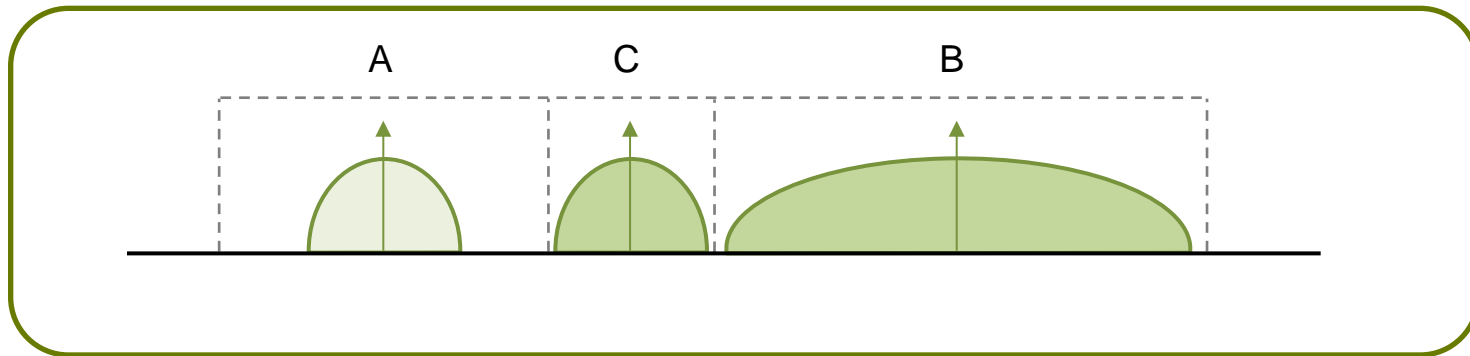
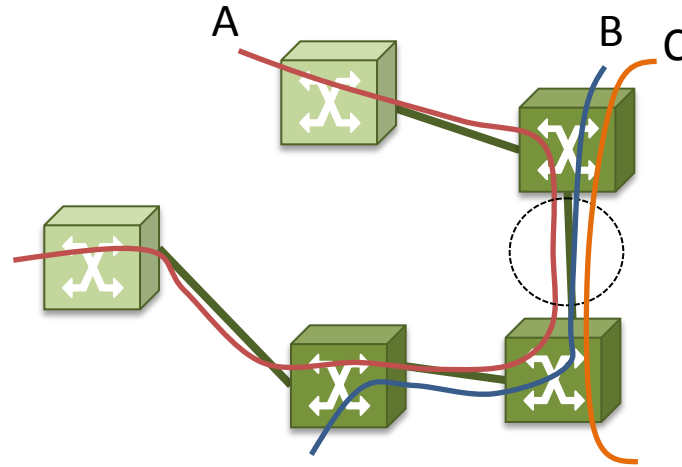

Migrating connections (4/4)

Mixed grid

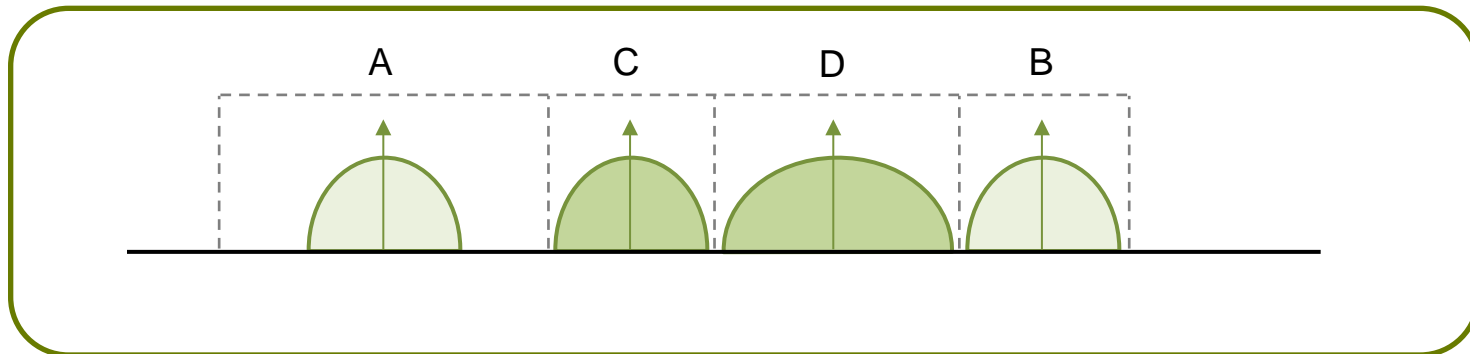
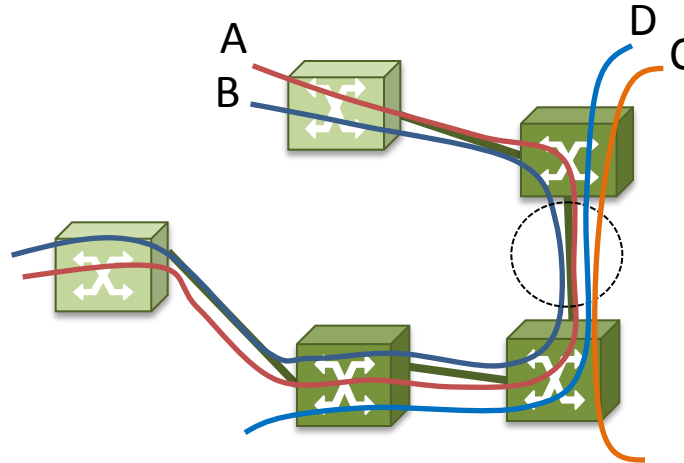

Migration flow chart

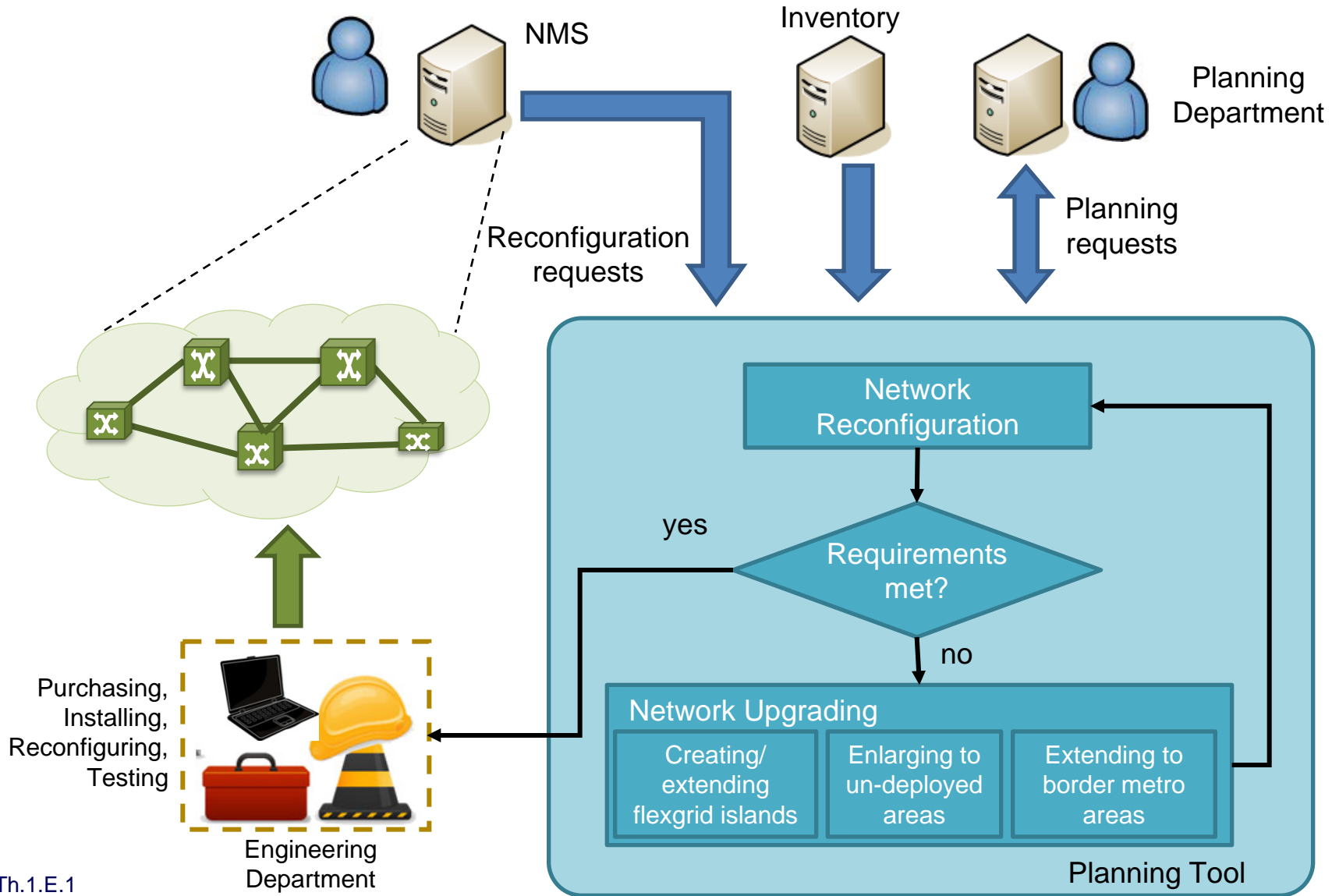



UNIVERSITAT POLITÈCNICA
DE CATALUNYA

Optical
Communications
Group



Part V

In-operation Network Planning

Luis Velasco

Static Network Operation

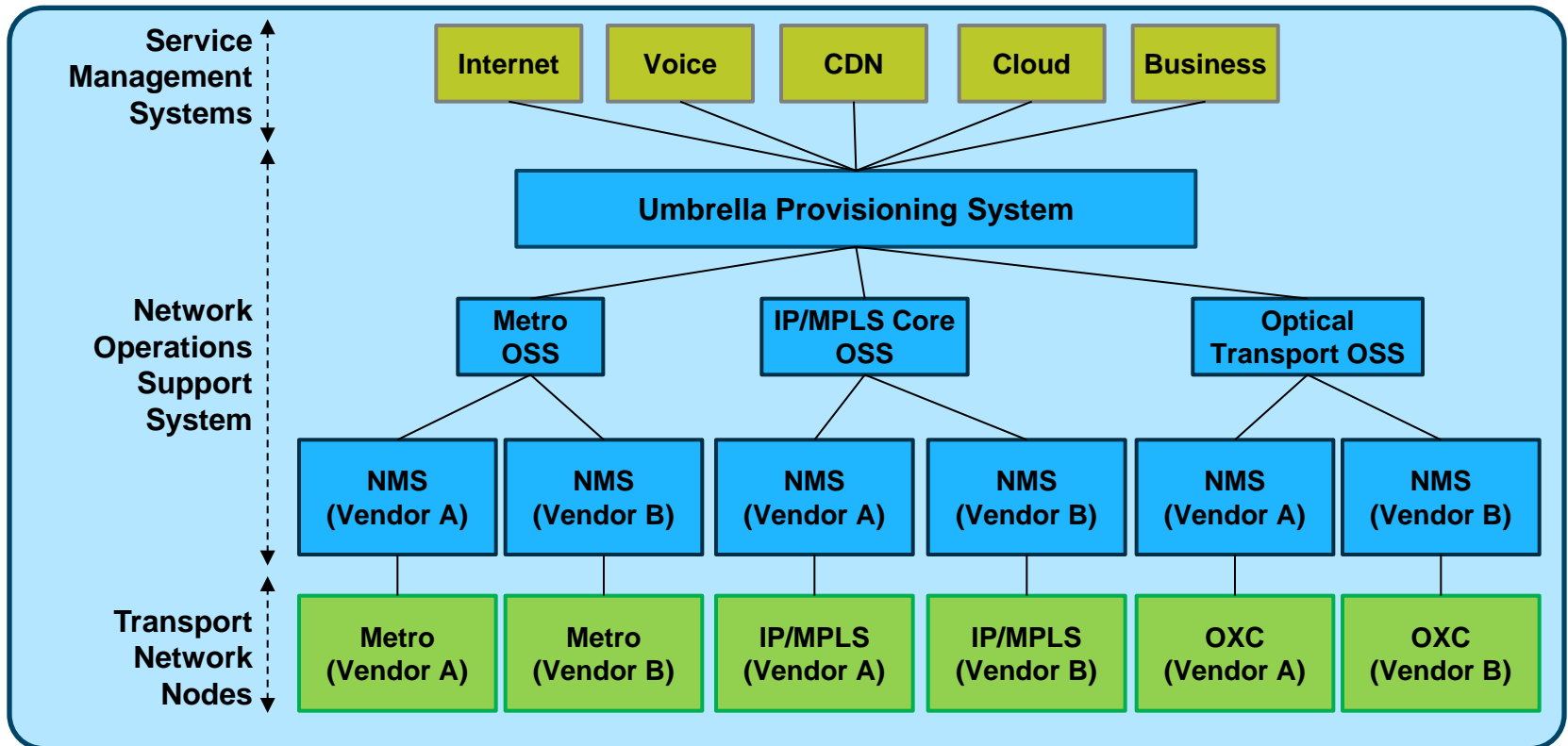

IETF architectures supporting in-operation Planning (1/2)

Architecture	Strengths	Weaknesses
Stateless PCE	<ul style="list-style-type: none"> • Path computation can be off-loaded onto a dedicated entity capable of complex computations with tailored algorithms and functions. • Has a standard and mature interface and protocol. • Supports simple optimisation, such as bulk path computation. 	<ul style="list-style-type: none"> • Is unaware of existing LSPs and has no view of the current network resource utilisation and key choke points. • Cannot configure by itself any LSP in the network. • Delays need to be introduced to sequence LSP set-up.
Stateful PCE	<ul style="list-style-type: none"> • Maintains a database of LSPs that are active in the network, i.e. so that new requests can be more efficiently placed optimising network resources. • Supports optimization involving already established LSPs. 	<ul style="list-style-type: none"> • More complex than a stateless PCE, requires additional database and synchronization. • No existing LSPs can be modified, e.g. for network re-configuration purposes.

IETF architectures supporting in-operation Planning (2/2)

Architecture	Strengths	Weaknesses
<p>Active Stateful PCE</p>	<ul style="list-style-type: none"> • Capable of responding to changes in network resource availability and predicted demands and reroute existing LSPs for increased network resource efficiency. • Supports complex reconfiguration and re-optimization, even in multilayer networks. 	<ul style="list-style-type: none"> • No new LSPs can be created, e.g. for VNT re-optimisation purposes. • Requires protocol extensions to modify and/or instantiate (if the capability is available) LSPs.
<p>ABNO</p>	<ul style="list-style-type: none"> • Provides a network control system for coordinating OSS and NMS requests to compute paths, enforce policies, and manage network resources for the benefit of the applications that use the network. • New LSPs can be created for in-operation planning. VNTM in charge of VNT re-configuration. • Supports deployment of solutions in multi-technology scenarios (NetConf, OpenFlow, control plane, etc.) 	<ul style="list-style-type: none"> • Requires implementation of a number of key components in addition to the PCE function. • Some interfaces still need to be defined and standardized.

Migration towards in-operation network planning

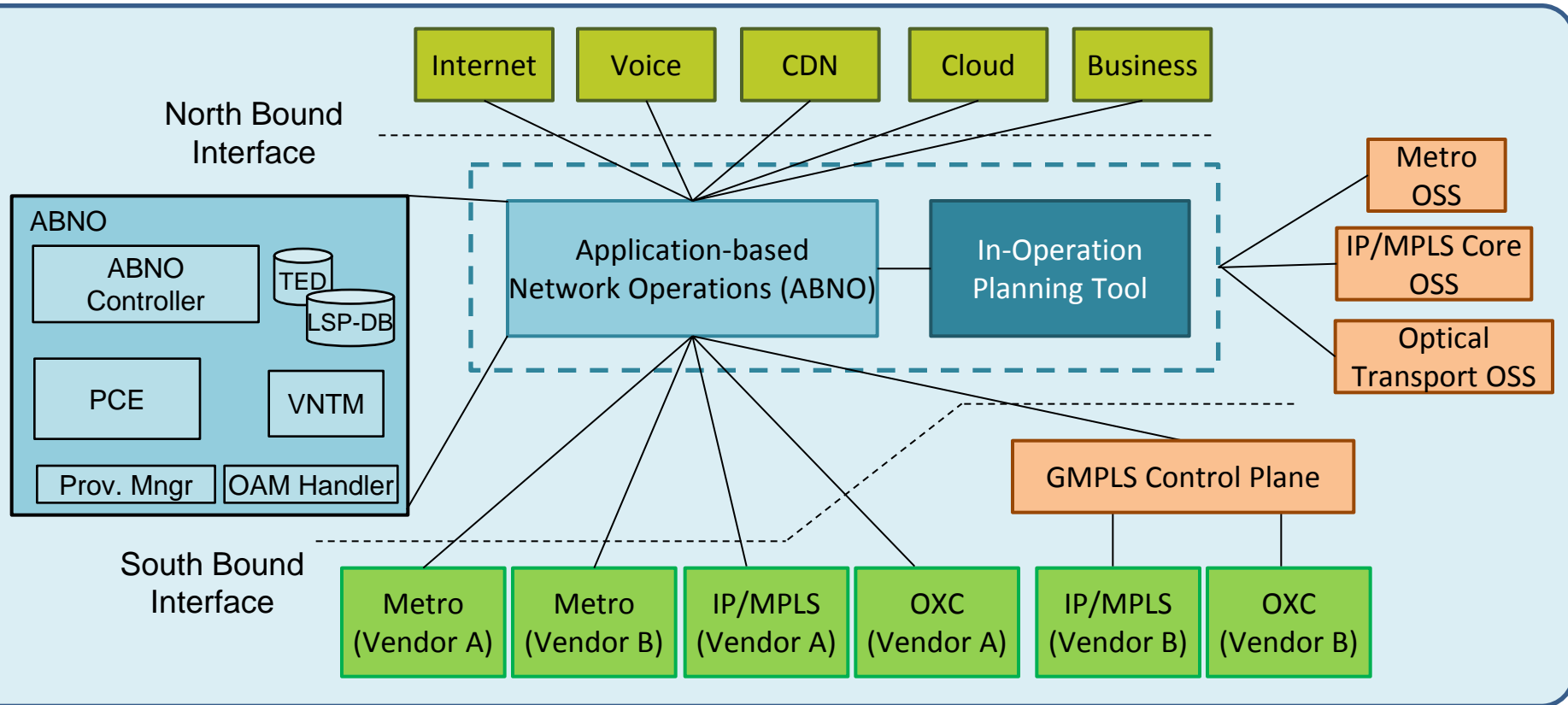

Extended Networks Life Cycle

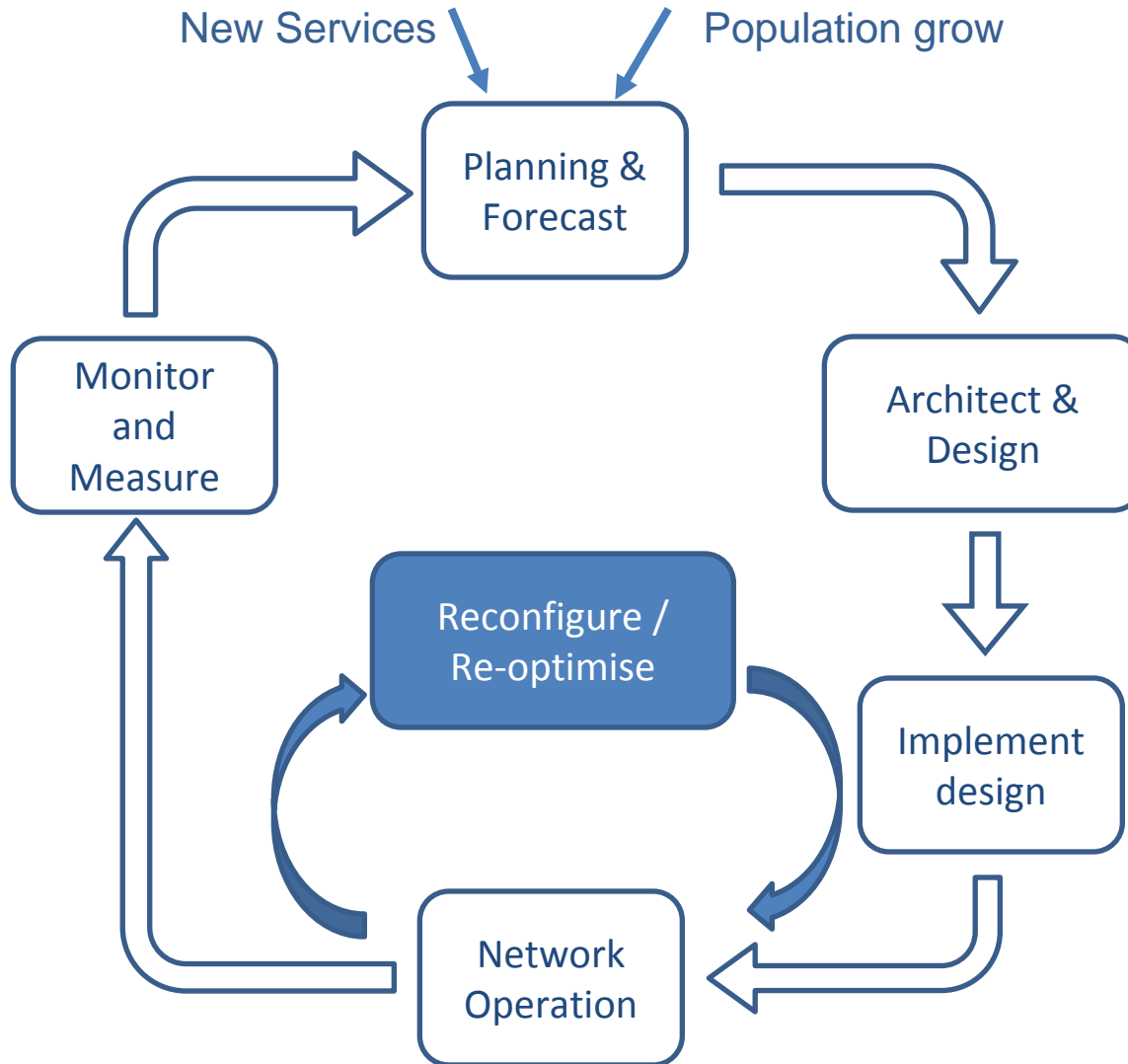

Re-optimisation Process

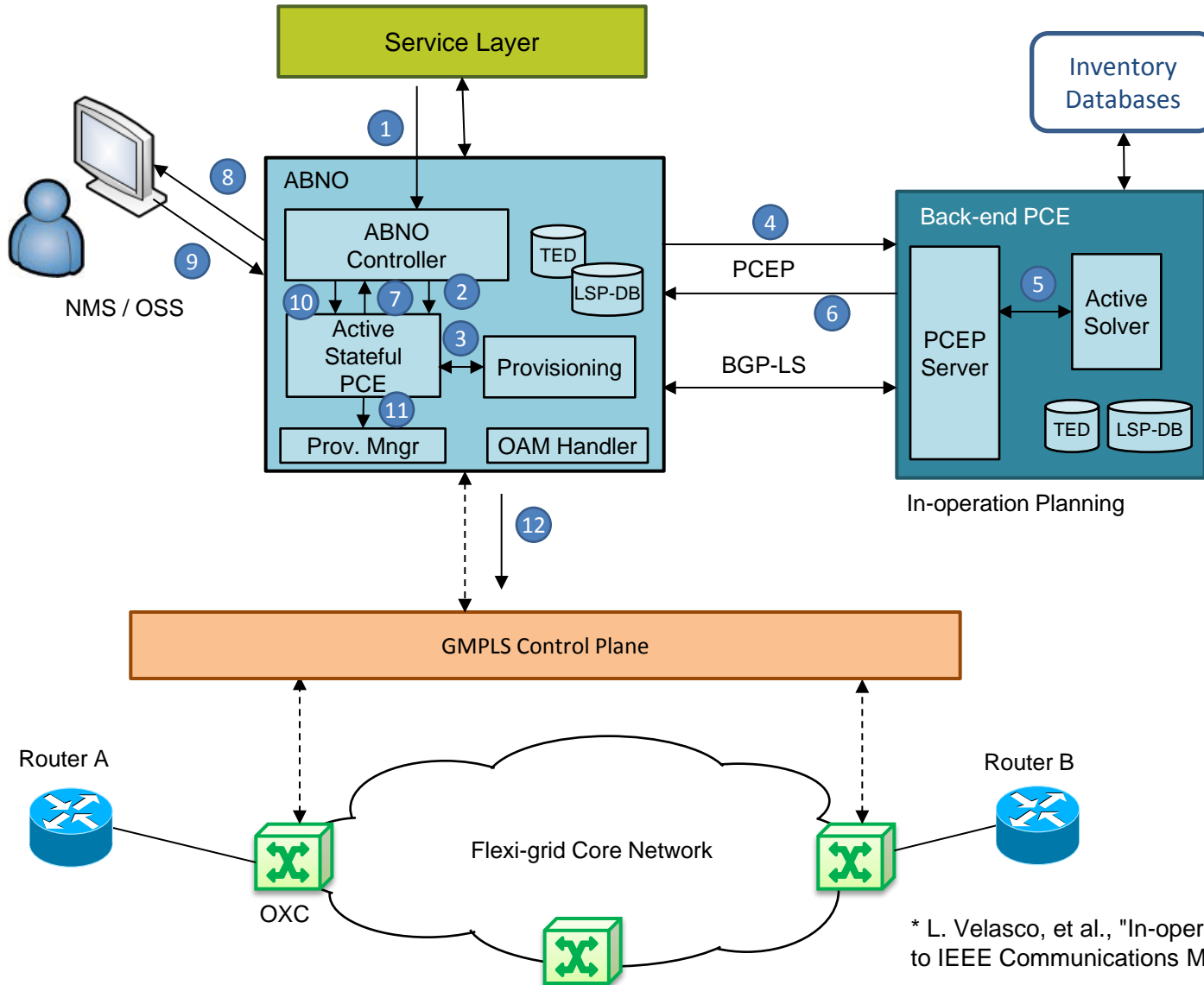

* L. Velasco, et al., "In-operation Network Planning," submitted to IEEE Communications Magazine, 2014.

In-Operation Planning Tool: PLATON

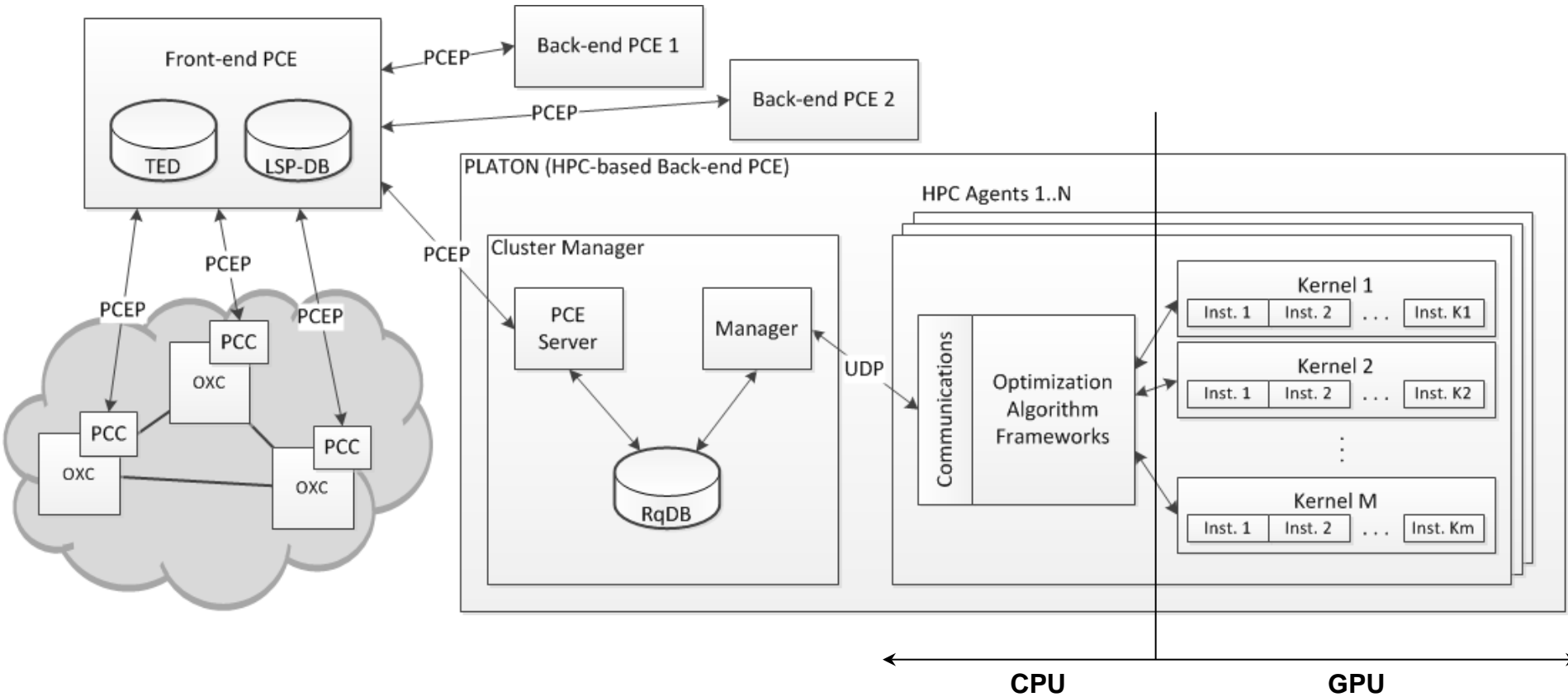

* L. Gifre, et al. "Architecture of a Specialized Back-end High Performance Computing-based PCE for Flexgrid Networks," in Proc. IEEE International Conference on Transparent Optical Networks (ICTON), 2013.

Conclusions

- **Basic RSA algorithms have been reviewed**
- **Elastic SA:** Semi-elastic and Elastic policies
- **Off-line planning:** and example for gradual migration process from fixed to Flexgrid has been presented.
- **Re-optimization** can be performed to increase network performance.
- A control and management architecture to support **in-operation planning**.
 - The architecture allows dynamic network operation and to reconfigure and re-optimize the network near real-time in response to changes.
 - Networks life cycle is extended achieving better resource utilization.
 - Process automation reduces manual interventions and, consequently, OPEX.
- **PLATON:** an In-Operation Planning Tool has been presented.



UNIVERSITAT POLITÈCNICA
DE CATALUNYA

Optical
Communications
Group



Thank you for your attention!

Solving Routing and Spectrum Allocation Related Optimization Problems

Luis Velasco, Alberto Castro, Marc Ruiz
lvelasco@ac.upc.edu

